

Product specification



Certificate No. 387



BS 6222 Part 2
Licence No. 59287



Certificate No. 387



Supplier
TT-COC-2198



Allocated 25 year life assessment

fifteen cabinet specification

Richmond's manufacturing process is approved by ISOQAR to BS EN ISO 9001:2000 meeting the exacting requirements of the Furniture Industry Association (FIRA) Gold Award and manufactured under the BSI Kitemark.

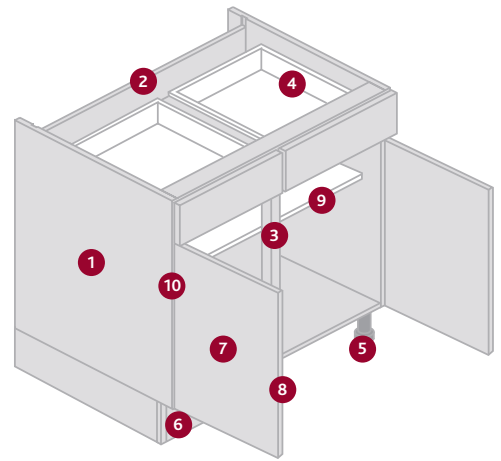

1 Carcase material

Panels are manufactured from 15mm fine surface chipboard to BS EN 312-2:2003.

Type P2 faced in 80 g/m² melamine, to comply with the requirements of BS EN 14322:2004.

Type P3 moisture resistant chipboard. Tested and conditioned in accordance with BS EN 312-8:2003 available on request.

Tested to conform to BS 6222: Part 3 for surface finish. All exposed edges lipped with melamine bonded with hot melt adhesive.

Brackets

All metal brackets manufactured from zinc-plated steel to BS 1706:1990 resistant to corrosion.

Carcase construction

Cam and dowel, fully repairable construction.

2 Unit backs

Removable inset MDF backs to all units with 70mm void (600mm deep units) and 40mm void (500mm deep units) for plumbing requirements. 15mm MFC solid back available as an optional extra.

3 Rails and Muntins

MDF Front rails, vertical muntins and cross muntins are fully wrapped with white foil.

4 Drawer system

Epoxy coated metal drawer box incorporating metal sides with 15mm MFC base and back, fully adjustable all metal fascia mounting brackets, metal runners with nylon rollers and integrated stop and self closing action.

5 Legs

Adjustable legs with 37mm travel to ensure an even finish.

6 Plinth

Base units have continuous plinth 150mm high with optional plinth return.

7 Fascias

Choice of 18 door and drawer fascias which are all fully adjustable with drawer line base doors, double handed fully interchangeable with standard wall units.

8 Fascia edging

MFC door edges lipped with environmentally friendly ABS edging for improved moisture resistance and a smooth finish.

9 Shelves

Fully adjustable for height, supported on nylon shelf pegs, central support provided for all double units to prevent deflection.

Handles

Choice of 16 handles in a variety of sizes.

10 Hinges

Clip-on, clip-off metal four-way adjustable self-closing 175° clip-on hinges. Metal mounting plates, secured to carcase by machine screws. Optional 110° clip-on hinges. Tested to BS 6222:Part 2 Level H.

Worktops

Choice of 10 colours at 30mm thickness and 11 colours in 40mm thickness both supplied in 3000mm lengths.

Product specification



Certificate No. 387



BS 6222 Part 2
Licence No. 59287



Certificate No. 387



Supplier
TT-COC-2198



Allocated 25 year life assessment

eighteen cabinet specification

Richmond's manufacturing process is approved by ISOQAR to BS EN ISO 9001:2000 meeting the exacting requirements of the Furniture Industry Association (FIRA) Gold Award and manufactured under the BSI Kitemark.

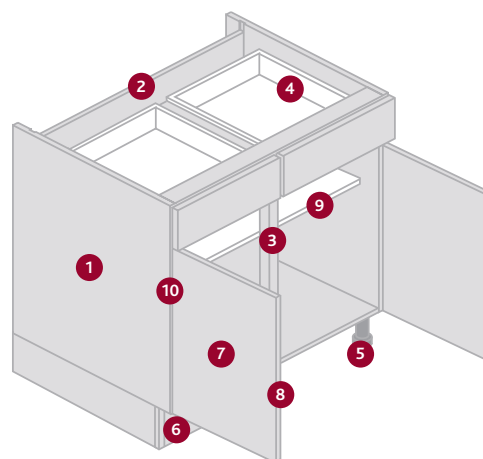

1 Carcase material	<p>Panels are manufactured from 18mm fine surface chipboard to BS EN 312-2:2003.</p> <p>Type P2 faced in 80 g/m² melamine, to comply with the requirements of BS EN 14322:2004.</p> <p>Type P3 moisture resistant chipboard. Tested and conditioned in accordance with BS EN 312-8:2003 available on request.</p> <p>Tested to conform to BS 6222: Part 3 for surface finish. All exposed edges lipped with melamine bonded with hot melt adhesive.</p>
Brackets	All metal brackets manufactured from zinc-plated steel to BS 1706:1990 resistant to corrosion.
Carcase construction	Cam and dowel, fully repairable construction.
2 Unit backs	Removable inset MDF backs to all units with 65mm void (600mm deep units) for plumbing requirements. 15mm MFC solid back available as an optional extra.
3 Rails and Muntins	MDF front rails, MFC vertical muntins and MFC cross muntins are fully wrapped with white foil.
4 Drawer system	Epoxy coated metal drawer box incorporating metal sides with 15mm MFC base and back, fully adjustable all metal fascia mounting brackets, metal runners with nylon rollers and integrated stop and self closing action.
5 Legs	Adjustable legs with 37mm travel to ensure an even finish.
6 Plinth	Base units have continuous plinth 150mm high with optional plinth return.
7 Fascias	Choice of 17 door and drawer fascias which are all fully adjustable with drawer line base doors, double handed fully interchangeable with standard wall units.
8 Fascia edging	MFC door edges lipped with environmentally friendly ABS edging for improved moisture resistance and a smooth finish.
9 Shelves	Fully adjustable for height, supported on nylon shelf pegs, central support provided for all double units to prevent deflection.
Handles	Choice of 16 handles in a variety of sizes.
10 Hinges	Clip-on, clip-off metal four-way adjustable self-closing 175° clip-on hinges. Metal mounting plates, secured to carcase by machine screws. Optional 110° clip-on hinges. Tested to BS 6222: Part 2 Level H.
Worktops	Choice of 10 colours at 30mm thickness and 11 colours in 40mm thickness both supplied in 3000mm lengths.